

## Metis MY45 / MY46

### Non-contact temperature measurement of flames and hot gases containing CO<sub>2</sub>

The pyrometer models **Metis MY45** and **MY46** with pyro-electric detectors are sensitive for IR-radiation in very narrow spectral bands. Both are especially suited to measure the temperature of hot CO<sub>2</sub> and, at the same time, avoid the absorption band of cold CO<sub>2</sub>. The working wave length will be optimally aligned to the precise application.

For recommendation we need to know concentration, layer thickness and temperature profile of CO<sub>2</sub>.

**Temperature ranges:** 400-1300°C  
500-1500°C  
500-2000°C



**Lenses:** The pyrometer is sensitive to infrared radiation in an area called cone of vision. This area has to be kept free from any intervening objects. The infrared energy radiated by the hot gas is centered via focusable or fixed focus lenses directly on the detector. The focusing feature allows control of the cone of vision and offers the possibility to measure either a small spot (focused) or the average of a bigger spot (out of focus).

**Chart 1: Focusable Lenses Metis MY45 / 46**

Lens	Distance	Spot size diameter Ø Standard temp. ranges
OM45-D0	190 mm	2.5 mm
	400 mm	5.6 mm
	900 mm	12.6 mm
OM45-L0	250 mm	3.3 mm
	1500 mm	18 mm
	4000 mm	48 mm

For the spot size diameter Ø at shortest, medium and widest focal distance, please see Chart1. For full scale temperatures up to 1300°C the cone of vision diameter in front of the lens is about 16 mm and about 9 mm for full scale temperatures above. The spot size diameter for distances not given in the chart can be calculated by interpolation.

Fixed focus lenses with larger diameter collect more infrared energy and therefore result in smaller spot sizes. (Chart 2)

The lenses are made of CaF<sub>2</sub> (calcium fluoride) which is highly transparent in visible region also. If additional windows are necessary they must offer similar optical characteristics.

**Chart 2: Fixed-Focus lenses of Metis MY45 / 46**

Lens	Aperture Ø	Distance	Spot size Ø	
			MB13./ 15	MB20
OM45-0E	16 mm	1200 mm	7.5 mm	6 mm
OM45-0G	16 mm	800 mm	4.5 mm	4 mm
OM45-0D	16 mm	600 mm	3.5 mm	3 mm

**Optical Alignment:** For the optical alignment of the pyrometer to the measured object, there are two alternatives: The first method is the built-in laser pointer which is helpful in dark environments. For measurement tasks which make the inspection of the optical alignment during operation necessary, we recommend the version with through the lens sighting.

**Output Signals:** Metis Pyrometers offer a variety of analogue and digital output signals for displaying, controlling and archiving of measured process temperatures. The galvanically isolated analogue output is selectable from 0-20 mA or 4-20 mA. Start and end of the application for the customers required temperature span can be freely set-up within the stated temperature range. Minimum span: 51°C.

There is a choice of 2 digital communication interfaces: **RS232** or **RS485** with a maximum of 19.2 kBd.

**Software:** The **SensorTools** software is standardly available for the automatic, process-reliant, parameters of the pyrometer, for the display and for the graphic and tabular file recording of the measured temperatures. At the same time, these files can be used for quality assurance purposes since the pyrometers parameter settings are recorded as well.

**System requirements:** PC with min Windows 7.

## Technical Data

Temperature ranges	400-1300°C, 500-1500°C and 500-2000°C
Measurement uncertainty	1°C + 0.5% - ( $T_a = 23^\circ\text{C}$ , $\varepsilon = 1$ , $t_{90} = 1 \text{ s}$ )
Repeatability	0.1% of measured temperature in °C + 1°C - ( $T_a = 23^\circ\text{C}$ , $\varepsilon = 1$ , $t_{90} = 1 \text{ s}$ )
Response time $t_{90}$	100 ms adjustable up to 10 s
Analogue output signal	0 or 4 – 20 mA selectable, max. Load: 500 $\Omega$
Digital communication:	RS232 or RS485 (half duplex) 19.2 kBaud max
Emissivity range:	0.20 – 1.00
Temperature resolution	Analog: < 0.1% adjusted temperature range, digital: 0.1°C
Power Supply	24 V AC/DC (15 – 30 V AC/DC), AC: 48 – 62 Hz, max. 2.5 VA
Isolation	power supply, analogue and digital outputs are galvanically isolated from each other and from the housing
Laser aiming light (option):	$\lambda=650 \text{ nm}$ , < 1 mW, class II per IEC 60825-1-3-4
Weight	700 g
Housing and rating	Aluminum, IP65 per DIN 40 050
Ambient temperature	Pyrometer: operation: 0 – 70°C, storage: -20 – 80°C
Rel. humidity:	No condensing conditions
CE label	According to EU directives for electromagnetic compatibility (EMC)

With the model **MY47**, a **TÜV** certified version according to DIN EN 15267-3 [1] is available.

## Dimensions:

**Metis MY** with Focusable Lens and **Swivel Base HA20** (accessory)

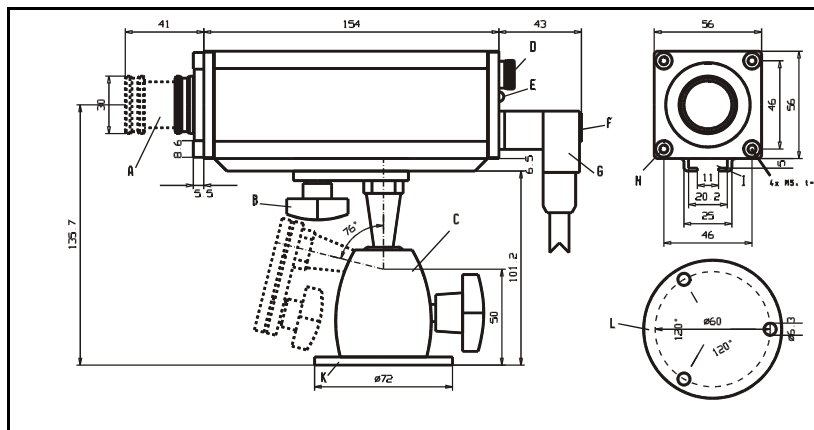

- A: Focusable Lens
- B: Fast-Mount Screw
- C: Swivel Mounting Base
- D: Eye Piece (sight-through optics)
- E: Operation LED
- F: Laser Push Button
- G: 12-pin Connector
- H: Front-Mount Threads
- I: Mounting Rail
- K: Swivel Base Mounting Flange
- L: Base View of item K with Mounting Holes
- M: Mounting Bracket

**Water Cooling Jacket accessory KG10**  
for use in ambient temperatures up to 200°C



**Metis MY45** with Fixed Focus Lens and **Mounting Bracket HA10** (accessory)

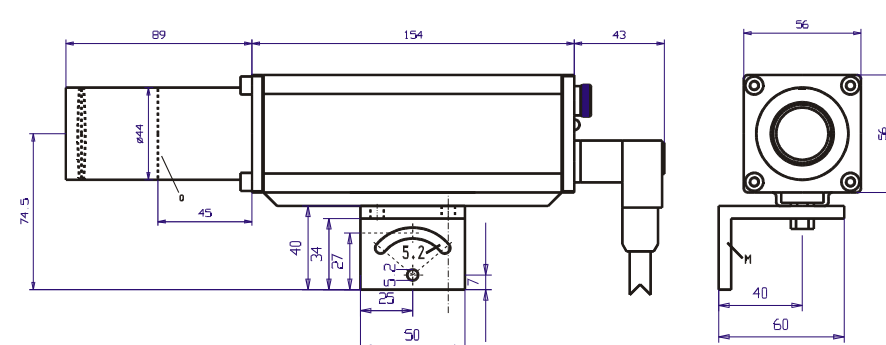

**Sensortherm GmbH**  
Infrared Temperature Measurement  
and Control  
Hauptstr. 123, D-65843 Sulzbach/Ts  
Tel.: +49 (0)6196 64065-80  
Fax: +49 (0)6196 64065-89  
[info@sensortherm.com](mailto:info@sensortherm.com)  
[www.sensortherm.com](http://www.sensortherm.com)

Depending on model, the lens tube length is either 45 mm or 89 mm.

Specifications are subject to change without notice. Sensortherm-Datasheet\_Metis\_MY45\_MY46 (Aug. 17, 2016)