

Metis MY34

Special Applications

The pyrometer **Metis MY34** using pyroelectrical detectors operate in a narrow band around 3.43 μm . It is developed especially to take advantage of unusual absorption or transmission features of certain materials.

Among other reasons, standard quartz glasses also differ in their transmission properties within the short-wave infrared area. Some types of glass are available with high enough transmission at 3.43 μm to perform measurements but others are low enough to protect from unwanted radiation originating from warm sources. In semiconductor production one can find a wide application range for the Metis MY34 product line.

Further application is the measurement on thin plastic foils using a characteristic CH absorption range, e.g., polybutylene, polystyrene, polyurethane, vinyl and nylon.

Chart 1: Temperature range and spectral response

Model	MY34
Spectral range	3.43 μm
Temperature range	300 – 1300°C



Objective:

The infrared energy radiated by the target is centered via focusable or fixed focus lenses directly on the detector. The focusing feature allows control of the cone of vision and offers the possibility to measure either a small spot (focused) or the average of a bigger spot (out of focus). The lenses are made of calcium fluoride CaF_2 which is highly transparent in visible and infrared regions up to 10 μm . Measurements through additional windows must offer similar optical characteristics.

Chart 2: Focusable Lenses

Objective	Measuring distance	Spot size diameter
OM34-D0	182 mm	1.2 mm
	480 mm	2.4 mm
	780 mm	6 mm
Aperture		ca. 16 mm

The distances for each smallest possible spot size diameter are exemplary, they can be adjusted continuously. Measuring distances not shown in the table are determined by interpolation.

The detector is sensitive to infrared radiation in an area called the cone of vision. For the spot size diameter of the cone of vision at shortest, medium and widest focal distances, please see Chart 2. The cone of vision diameter in front of the lens is about 16 mm. This area has to be kept free from any intervening objects.

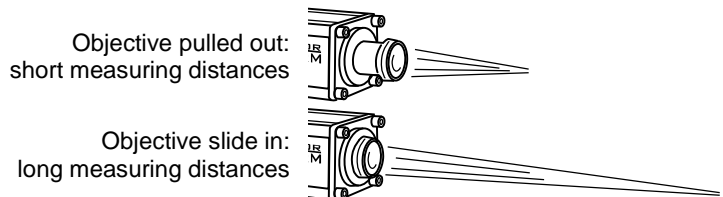

Optical Alignment

Metis MY Pyrometers are available with 2 different solutions for aiming the sensor onto the target. The first and most popular method is the built-in laser aiming light. The second solution is a sight-through optics version with reticle-defined target which is advantageous for applications where aiming onto hot, incandescent targets is needed.

Temperature Output Signals

Metis Pyrometers offer a variety of analog and digital output signals for displaying, recording, archiving and controlling of measured process temperatures. The isolated analog output is selectable from 0 to 4 - 20 mA. Zero-scale and full-scale temperatures are adjustable to cover any portion of the instrument's available temperature span to a minimum of 50°C.

There is a choice of 2 digital communication interfaces: **RS232** or **RS485** max. 19.2 kBd.

Signal Filtering:

For measuring and holding of the highest instantaneous temperature value a peak picker (maximum value storage) is installed to compensate interruptions or attenuations in radiation caused by bursts of steam, smoke or dust. It can be reset either automatically or manually by an external contact closure or periodically by user preset clear time. In the last case the highest temperature will be held in a dual storage and will be reset in only one of the two storages after preset clear time to avoid a decrease of the temperature output, should a short cold period appear just at the reset moment.

Software:

The **Sensorwin Software** is available in scope of delivery for automatic or manual set up of the pyrometer, for recording and for saving of graphical or table files. At the same time these files can be used for quality assurance purposes because the parameter settings are recorded, too.

Minimum computer requirements: 500 MHz clock frequency and a current Windows operating system.

Technical Data

Temperature range	300 – 1300°C
Spectral range	3.43 µm
Measurement uncertainty	1°C + 0.5% of measured temperature (T _{Amb.} = 23°C, ε = 1, t ₉₀ = 1 s)
Repeatability	0.1% of measured temperature in °C + 0.2°C (T _{Amb.} = 23°C, ε = 1, t ₉₀ = 1 s)
Response time t ₉₀	100 ms, adjustable up to 10 s
Emissivity ε	0.20 – 1.00, adjustable
Analog output	0 or 4 – 20 mA selectable, max. load 500 Ω
Digital interface	RS232 or RS485, max. 19.2 kBd
Temperature resolution	Analog: < 0.1% of adjusted temperature range, Digital 0.1°C
Power supply	24 V AC/DC (12 – 30 V AC/DC), AC: 48 – 62 Hz, max. 2.5 VA
Isolation	Power supply, analog and digital output are galvanically isolated against each other and against housing
Laser aiming light	(optional) 650 nm, < 1 mW, class II per IEC 60825-1-3-4
Weight	700 g
Housing and protection class	Aluminum, IP65 per DIN 40 050
Ambient temperature	Operation 0 – 70°C, Storage -20 – 80°C
Rel. humidity:	No condensing conditions
CE label	according to EU directives about electromagnetic immunity

Dimensions

Metis MY with Focusable Lens and optional Swivel Base HA20

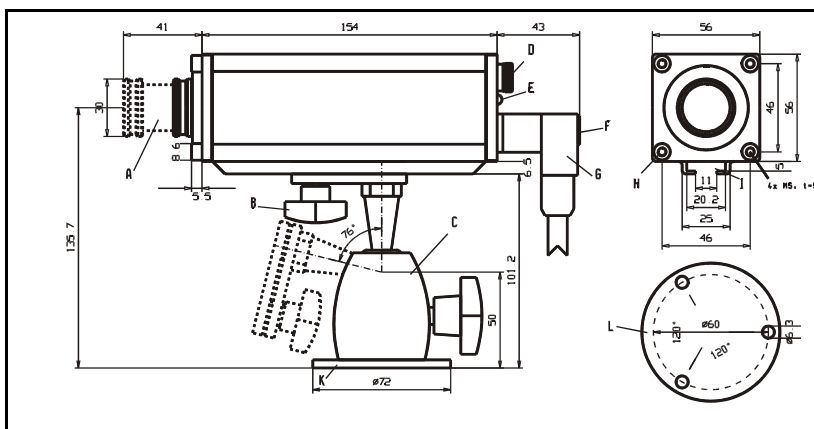

- A: Focusable Lens
- B: Fast-Mount Screw
- C: Swivel Mounting Base
- D: Eye Piece (sight-through optics)
- E: Operation LED
- F: Laser Push Button
- G: 12-pin Connector
- H: Front-Mount Threads
- I: Mounting Rail
- K: Swivel Base Mounting Flange
- L: Base View of item K with Mounting Holes
- M: Mounting Bracket

Accessory: Water Cooling Jacket KG10
for use in hot ambient temperatures up to 200°C



For mounting and protecting of Metis pyrometers additional accessories are available.