

Metis MB39

Special Applications

At a wavelength of **3.95 µm** hot furnace gases and clean burning gas flames are quite transparent and therefore permit temperatures of substances to be measured as well during the heating up process in industrial furnaces when using the Metis MB39 series. The **Metis MB39** uses this narrow range, so that metal parts or glass ceramics can be measured through flames and combustion gases.

Further the device is used for measurement of glass. In difference to conventional glass devices that measure glass surfaces at 5.14 µm, with 3.95 µm a slightly intruding measurement into glass is possible (e.g. for glass drop measurements).



Objectives:

The infrared energy radiated by the target is centered via focusable or fixed focus lenses directly on the detector. The focusing feature gives you control of the cone of vision and offers the possibility to measure either a small spot (focused) or the average of a bigger spot (out of focus). Fixed focus lenses with larger diameter collect more infrared energy and therefore result in smaller spot sizes.

The lenses are made of calcium fluoride CaF₂ which is highly transparent in the visible spectral region. If additional windows are necessary, they must offer similar optical characteristics.

Chart 1: Focusable Lenses

Lens	Measuring distance	Spot size diameter	
		500–2500°C	150–1000°C
OM39-A0	83 mm	0.7 mm	1.3 mm
	93 mm	0.8 mm	1.45 mm
	104 mm	0.9 mm	1.6 mm
OM39-B0	130 mm	1.1 mm	2 mm
	165 mm	1.6 mm	2.9 mm
	195 mm	2.0 mm	3.6 mm
OM39-C0	350 mm	3.0 mm	5.5 mm
	600 mm	6.0 mm	11 mm
	1000 mm	10.5 mm	19 mm
	2000 mm	22 mm	40 mm
	4000 mm	46 mm	83 mm

The detector is sensitive to infrared radiation in an area called the **cone of vision**. For the spot size diameter of it at shortest, medium and widest distances, if focused, please see **chart 1**. The distances for each smallest possible spot size diameter are exemplary, they can be adjusted continuously. Measuring distances not shown in the table are determined by interpolation.

Objective pulled out:
short measuring distances

Objective slide in:
long measuring distances

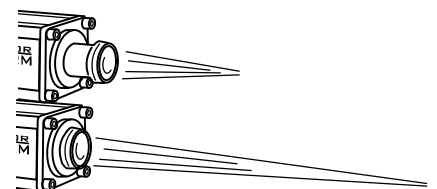

The cone of vision diameter in front of the lens is about 16 mm. This area has to be kept free from any intervening objects.

Optical Alignment:

Metis MB pyrometers are available with 2 different solutions for aiming the sensor onto the target. The laser allows a straight-forward alignment to the measuring object with the restriction that the red target light is not visible anymore on objects with temperatures from about 750°C. The second is a sight-through optics version with reticle-defined target which is advantageous for applications where aiming onto hot, incandescent targets is needed.

Temperature Output Signals:

Metis pyrometers offer a variety of analog and digital output signals for displaying, recording, archiving and controlling of measured process temperatures. The isolated analog output is switchable from 0 to 4 to 20 mA. Zero- and full-scale temperatures are adjustable to cover any portion of the instrument's available temperature span to a minimum of 50°C.

There is a choice of 2 digital communication interfaces: **RS 232** or **RS 485** max. 57.6 kBd (optional Profibus DP).

PID Controller:

The pyrometer can be equipped with PID control output signal instead of the analog temperature output signal 0/4 – 20 mA. The control features and functions can be operated manually by PC or automatically by digital commands. The auto tune feature automatically determines the P, I and D control parameters. If PID option is chosen, the temperature information will be available from the pyrometer only via digital interface.

Signal Filtering:

For measuring and holding of the highest instantaneous temperature value a **peak picker** (maximum value storage) is installed to compensate interruptions or attenuations in radiation caused by bursts of steam, smoke or dust. It can be reset either automatically or manually by an external contact closure or periodically by user preset clear time. In this last case the highest temperature will be held in a dual storage and will be reset in only one of the two storages after preset clear time to avoid a decrease of the temperature output, should a short cold period appear just at the reset moment.

Software SensorWin:

The software *SensorWin* is available for automatic or manual set up of the pyrometer, for recording and for storing of graphical or table files. At the same time these files can be used for quality assurance purposes because the parameter settings are recorded, too.

Minimum computer requirements: 500 MHz clock frequency and a current Windows operating system.

Technical Data

Temperature ranges:	150-1000°C 500-2500°C
Spectral response:	3.95 µm
Measurement uncertainty:	< 400°C: 2°C; > 400°C: 0.5 % of measured value in °C, (T _{Amb.} = 23°C, ε = 1, t ₉₀ = 1 s)
Repeatability:	0.1% of measured value in °C + 1 K, (T _{Amb.} = 23°C, ε = 1, t ₉₀ = 1 s)
Response time t ₉₀ :	3 ms with dynamic adaptation at low signal levels, adjustable up to 10 s
Emissivity ε:	0.05 - 1.00, adjustable
Analog output signal:	0 or 4 – 20 mA selectable, 500 Ω max. load
Digital interface:	either RS 232 or RS 485 max. 57,6 kBd; optional Profibus DP
Temperature resolution:	analog < 0.1% of adjusted temperature range, digital 0.1°C
Power supply:	24 V AC/DC (15 – 30 V AC/DC), AC: 48 – 62 Hz, max. 7 VA
Isolation:	power supply, analog and digital output are galvanically isolated against each other and against housing
Laser aiming light (option):	650 nm, < 1 mW, class II per IEC 60825-1-3-4
Weight:	600 g
Housing and protection class:	Aluminum, IP65 per DIN 40 050
Ambient temperature:	operation 0 – 53°C, storage -20 – 60°C
Rel. humidity:	No condensing conditions
CE label:	according to EU directives for electromagnetic immunity

Dimensions: Metis MB39 with Focusable Lens and Swivel Base HA20

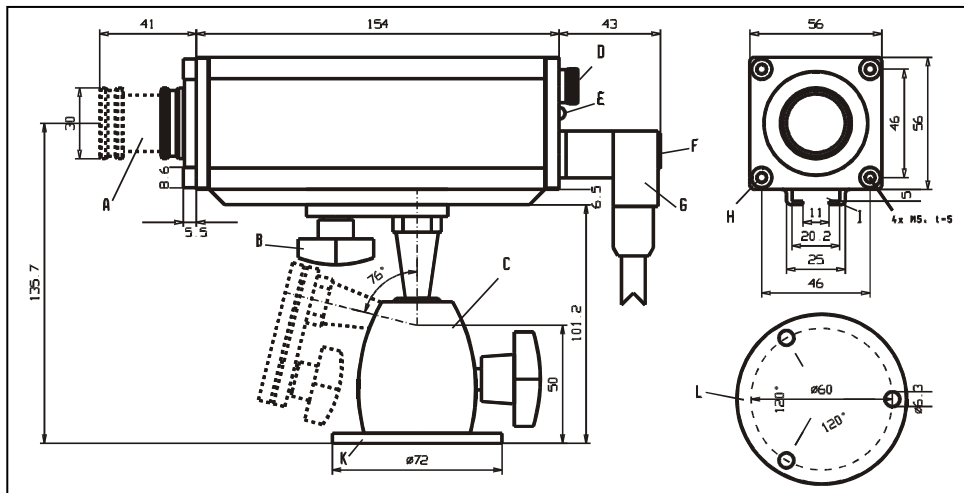

- A: Focusable lens
- B: Fast-Mount screw
- C: Swivel mounting base
- D: Eye piece (for models with sight-through optics only)
- E: Operation LED
- F: Laser push button
- G: 12-pin connector
- H: Front-mount threads
- I: Mounting rail
- K: Swivel base mounting flange
- L: Base view of item K with mounting holes
- M: Mounting bracket

Sensortherm GmbH

Infrared Temperature Measurement
and Control
Hauptstr. 123, D-65843 Sulzbach/Ts
Tel.: +49 (0)6196 64065-80
Fax: +49 (0)6196 64065-89
info@sensortherm.com
www.sensortherm.com