

MetisVision MV05 / MV09

Rugged Thermovision Camera for Industrial Applications

MetisVision **MV09** is a short-wave camera for the measurement of metals, ceramics, composites, semiconductors, wafers or molten glass.

Metis Vision **MV05** measures in even shorter wavelength range around 0.5 microns and is used in foundries for measurements of a liquid pouring stream.

Benefits at a glance:

- High accuracy, 0.5% of measured value
- Over 300,000 temperature measurement points
- Thermostated sensor offers extremely high, drift free stability
- Temperature ranges from 600°C up to 2000°C
- Focusable or fixed focus lenses
- Real time imaging up to 60 Hz update rate
- Gigabit Ethernet interface 1000 Mbit/s
- For Windows 7 Professional / Windows 8 Professional
- Easy handling
- Trigger input for remote controlled activation of measurement
- Extremely rugged housing with protection window, rated IP65

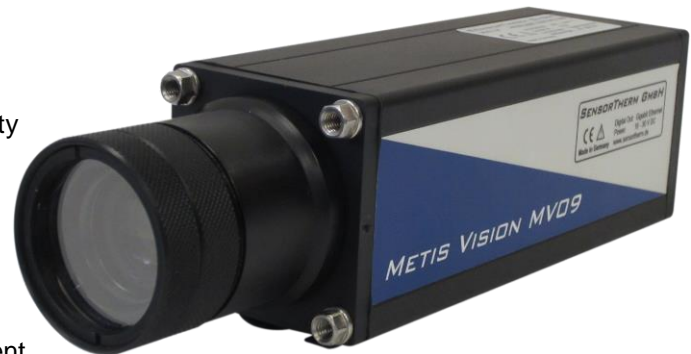

Application Example with ROI and Temperature Profiles

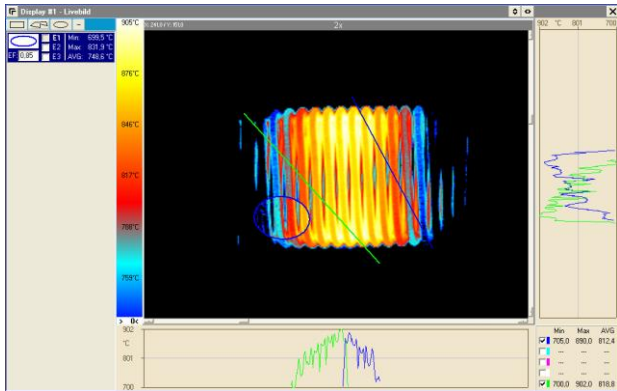

Processing Software *VisionWin*

- Automatically or manually temperature range adjustments
- Individually adjustable software images
- Emissivity adjustment range 0.20 - 1.00
- Adjustable external trigger function
- Up to **15** free drawn ROI's optional with analog output signals or alarms
- Line profiling, multiple color palettes, isothermal images
- Image comparison of several screenshots
- Capture and save functionality; CSV export

Technical Data

Model	MV05	MV09
Temperature ranges	1200–2000°C	600–1300°C 1200 – 2500°C 750–1500°C 1100 – 3000°C *) 900–1800°C (* Long temp. range)
Detector	Large radiometric format, 1/2" sensor for low noise signal	
Spectral range	0.35–0.6 µm	0.75–1.08 µm
Image update rate	max. 60 Hz	
Resolution	640 x 480 Pixels	
Digital communication	Gigabit Ethernet 1000 Mbit/s	
Measurement uncertainty	0.5% of measured value ($\epsilon = 1$, $t_{Amb.}$ 10–35°C)	
Temperature resolution	1K	
Lenses:	Fixed or adjustable focus (see chart next page)	
Emissivity ϵ	adjustable 0.1–1.00	
Power supply	24 V DC (16–30 V DC), 800 mA	
Input signal	Trigger input, remote controlled video recording or snap shot, optional via software adjustable	
Protection class	IP65	
Ambient temperature	0–50°C	
Storage temperature	-40–70°C	
Relative humidity	20–90%, none condensing	

MetisVision Optics Calibrated for Longer Measurement Distances

Model	OV09-A0		OV09-B0		OV09-C0		OV09-D0		OV09-E0		OV09-F0		OV09-G0	
FOV (deg)	hor.	vert.	hor.	vert.	hor.	vert.	hor.	vert.	hor.	vert.	hor.	vert.	hor.	vert.
	5°	3.5°	7.3°	5.5°	11°	8°	14°	11°	22°	17°	30°	22°	58°	44°
Min. focus dist.:	1 m		1 m		1 m		0.7 m		0.5 m		0.3 m		0.3 m	
Min. FOV mm	87	65	128	96	193	145	172	129	194	146	161	121	333	250
FOV @ 1 m	87	65	128	96	193	145	246	185	389	292	536	402	1109	832
FOV @ 2 m	175	131	255	191	385	289	491	368	778	584	1072	805	2217	1663
FOV @ 3 m	262	197	383	287	578	434	737	553	1166	875	1608	1206	3326	2495

MetisVision Optics Calibrated for Shorter Measurement Distances

Model	OV09-A1		OV09-B1		OV09-C1		OV09-D1		OV09-E1		OV09-F1		OV09-G1	
Focusable	0.7 – 1 m		0.9 – 1 m		0.35 – 1 m		0.25 – 0.7 m		0.25 – 0.5 m		0.25 – 0.3 m		0.2 – 0.3 m	
Min. FOV mm	61	46	115	86	67	50	61	46	97	73	134	101	222	162
Max. FOV mm	87	65	128	96	193	145	172	129	194	146	161	121	333	250

Optional 2 different calibration files can be supplied and uploaded depending on application distance.

Dimensions (in mm)

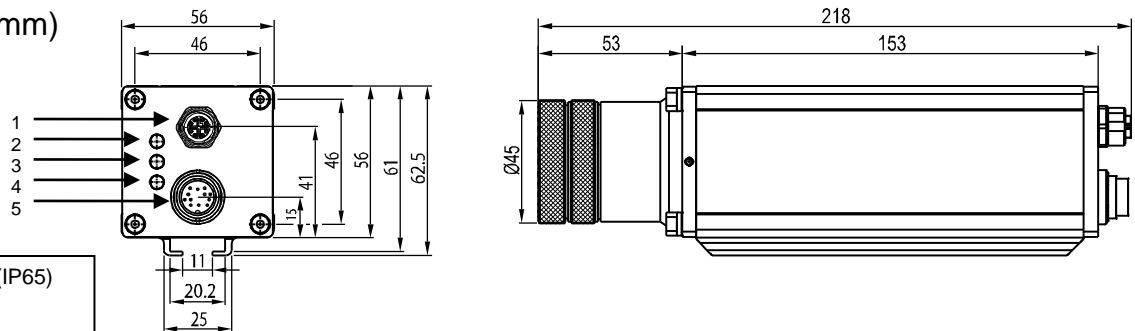

- 1 Ethernet connector (IP65)
- 2-4 Status LED's
- 5 12-pin connector for power supply and input / output signals

With Ethernet and connection cable AK 46, the measuring setup is extended by approx. 70 mm

Standard scope of supply:

- Metis Vision camera with lens of your choice
- VisionWin Software (**Minimum PC requirements:** I7 Processor, Dual Core, min. 2 x 2.9 GHz, 8 Gb RAM, HDD 500 Gb, SSD 240 Gb, optional, GBit Ethernet, resolution min 1024 x 768, Win 7, 8, 10)
- Manual

Accessories

	Item No.
Interconnecting cable for power supply and external trigger (xx = cable in 5 m long steps)	AK46-xx
Ethernet cable with RJ45 connector rated IP65 (xx = cable in 5 m long steps)	AK54-xx
Swivel base to be mounted to mounting rail of MV09 camera housing	HA20-00
Air purge accessory to be mounted to lens tube	BL10-00
Protection hood including water cooled front plate	KG31-00
Water-cooling or protection jacket with sapphire protection window	KG13-04
Air purge accessory to be mounted to sight tube of Water-cooling jacket KG16	BL12-00
Swivel base to be mounted to mounting rail of cooling jacket KG16	HA22-00

			Sensortherm GmbH Infrared Temperature Measurement and Control Hauptstr. 123 65843 Sulzbach/Ts Tel.: 0049-6196-64065-80 Fax: 0049-6196-64065-89 info@sensortherm.com www.sensortherm.com
Swivel base HA20-00	Water cooling jacket KG13 including air purge BL12	Swivel base HA22-00 to be used with KG13	