

Distribution and reproduction of this document, as well as Use or communication of the contents thereof, are forbidden unless expressly authorized. All rights reserved

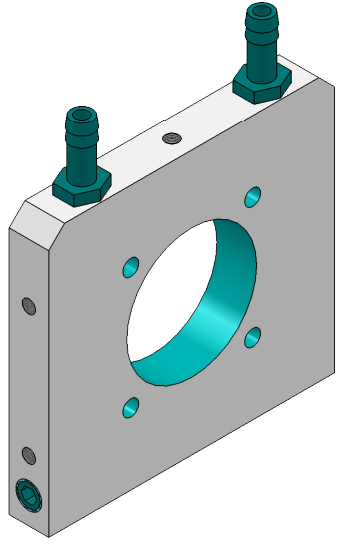
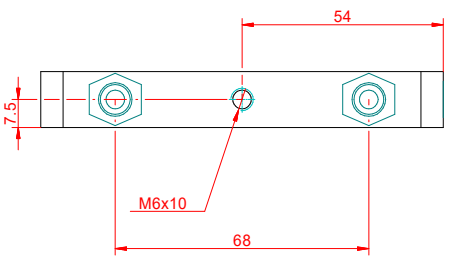
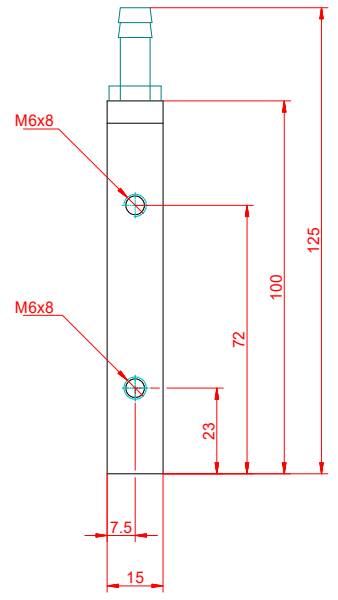
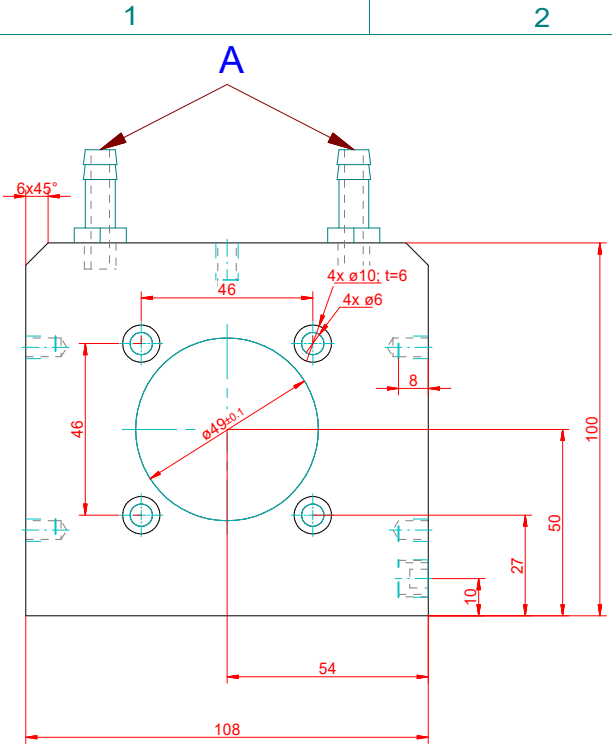

A: Schlauchanschluss mit Innendurchmesser 9mm

Connection for hose with 9mm inside diameter

Weitergabe und Vervielfältigung dieser Unterlage, sowie Verwertung und Mitteilung ihres Inhalts nicht gestattet, soweit nicht ausdrücklich zugestanden. Alle Rechte vorbehalten

		Maße in mm Dimensions in millimeters	Zul. Abw. f. Maße ohne Toleranzang. General tolerances	Fertigzustand finished condition	Maßstab Scale	Menge Quantity
			DIN ISO 2768 T1 m		1 : 2	.
					Rohstoff/Raw material Aluminium / Messing 0,23Kg	
					Rohteil-Nr./Raw piece No.	
					Werkzeug-Nr./Tool No.	
					Benennung/Designation	
					<b>KG 20 00 80</b>	
					Sachnummer/Part-No.	Blatt Sheet
					<b>ZN0353</b>	<b>1</b>
						von of
						<b>1</b>
Ausg. Issue	Änderung Modification	Datum Date	Name Name	Dateiname Filename	Ursprung Source	MegaCAD
				ZN035300 KÜhlgehäuse KG..prt	ZN0088	