

Copying of this document and giving it to others, and the use or communication of the contents thereof, are forbidden without express authority. All rights reserved.

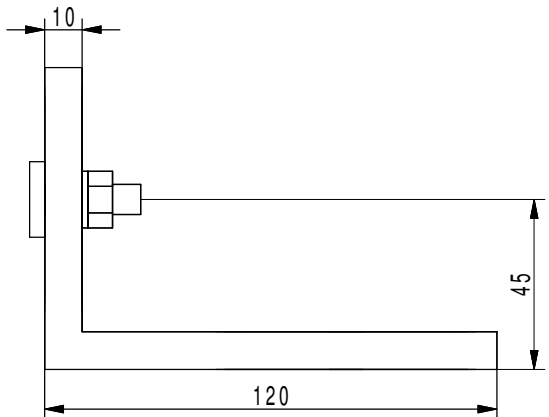

Montagesite für das Metis Kühlgehäuse

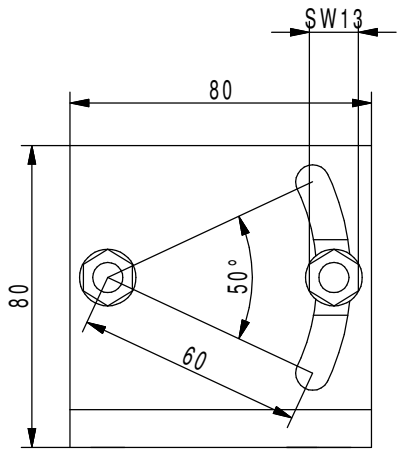
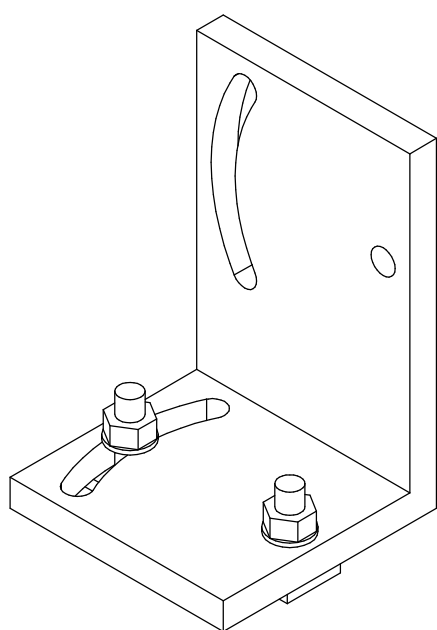
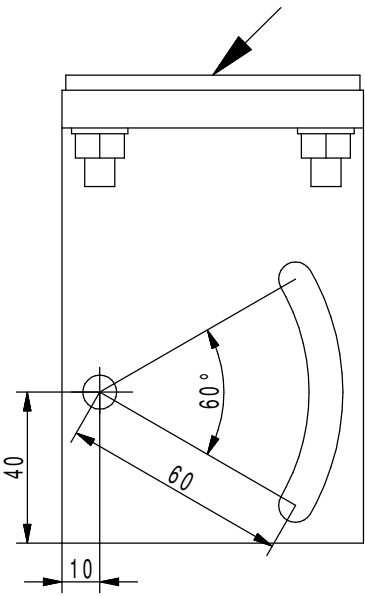

Weitergabe und Vervielfältigung dieser Unterlage, sowie Verwertung und Mitteilung ihres Inhalts nicht gestattet, soweit nicht ausdrücklich zugestanden. Alle Rechte vorbehalten

|                |                          |   |   |                                     |  |                     |
|----------------|--------------------------|---|---|-------------------------------------|--|---------------------|
|                |                          | Maße in mm<br>Dimensions in millimeters | Zul. Abw. f. Maße ohne Toleranzang.<br>General tolerances | Fertigzustand<br>finished condition | Maßstab<br>Scale 1:2                                 | Menge<br>Quantity . |
|                |                          |   |   |                                     | Rohstoff/Raw material<br>Rohteil-Nr./Raw piece No. . | Aluminium 0,4 Kg    |
|                |                          |   |   |                                     | Werkzeug-Nr./Tool No.                                |                     |
|                |                          |   |   |                                     | Benennung/Designation                                |                     |
|                |                          |   |   |                                     | <b>HA12-00</b>                                       |                     |
|                |                          |   |   |                                     | <b>Haltewinkel</b>                                   |                     |
|                |                          |   |   |                                     | Sachnummer/Part-No.                                  | Blatt<br>Sheet 1    |
|                |                          |   |   |                                     | <b>ZN0091</b>  | von<br>of 1         |
| Ausg.<br>Issue | Änderung<br>Modification | Datum<br>Date                           | Name<br>Name  | Dateiname<br>Filename               | Ursprung<br>Source                                   | MegaCAD             |
|                |                          |   |   | ZN009100_HA12-00.Prt                |  |                     |

