

### Anwendungsbeispiel (Example of Application)

A: Schlauchanschluss mit  
Innendurchmesser 8mm

Connection for hose with  
8mm inside diameter

Empfohlener Spülluftdurchsatz: 1,5m<sup>3</sup>/h  
Empfohlener Luftdruck: 0,5bar

Recommended air flow: 1,5m<sup>3</sup>/h  
Recommended air pressure: max. 0,5bar

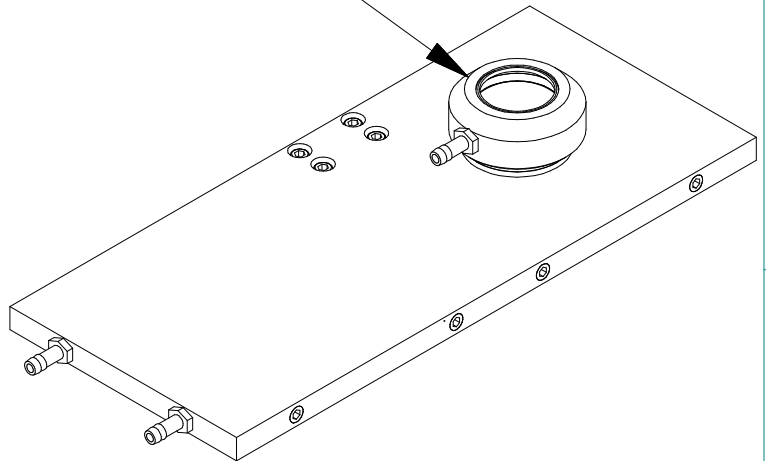

		Maße in mm Dimensions in millimeters		Zul. Abw. f. Maße ohne Toleranzang. General tolerances		Fertigzustand finished condition		Maßstab Scale <b>1 : 2</b>		Menge Quantity	
								Rohstoff/Raw material Aluminium		Rohteil-Nr./Raw piece No.	
								Gewicht/Weight: 4Kg			
				Bearb. Drawn		Datum Date		Name Name		Benennung/Designation	
				Gepr. Checked						BL12-01 Blasvorsatz für Kühlplatte Air Purge for cooling plate	
				Norm Approved						Sachnummer/Part-No. <b>ZN012600</b>	
										Blatt Sheet <b>1</b>	
										von of <b>1</b>	
Ausg. Issue		Änderung Modification		Datum Date		Name Name		Dateiname Filename		Ursprung Source	
								ZN012600 BL12-01.Prt		MegaCAD	