

Copying of this document and giving it to others, and the use or communication of the contents thereof, are forbidden without express authority. All rights reserved.

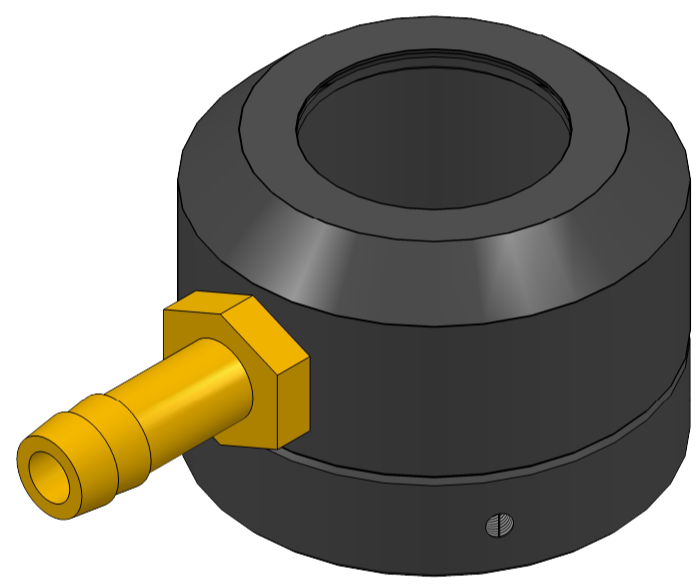
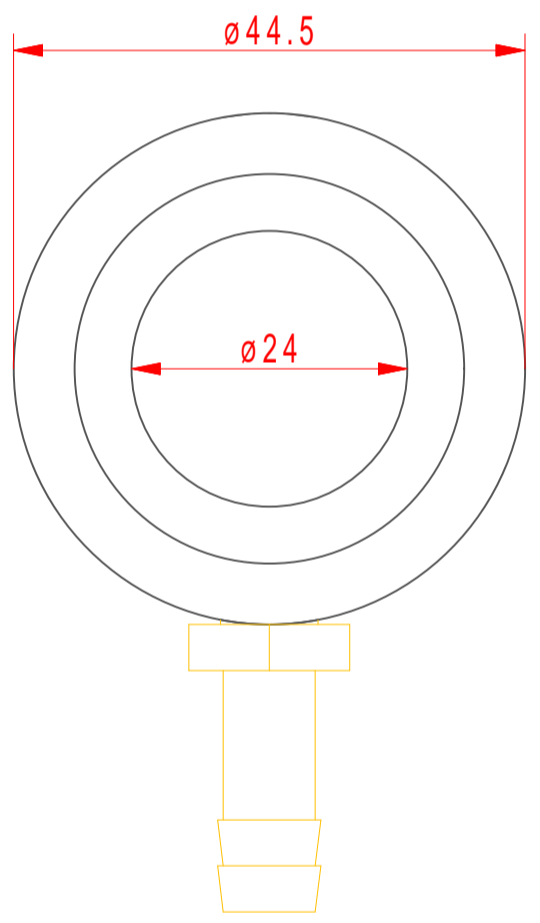
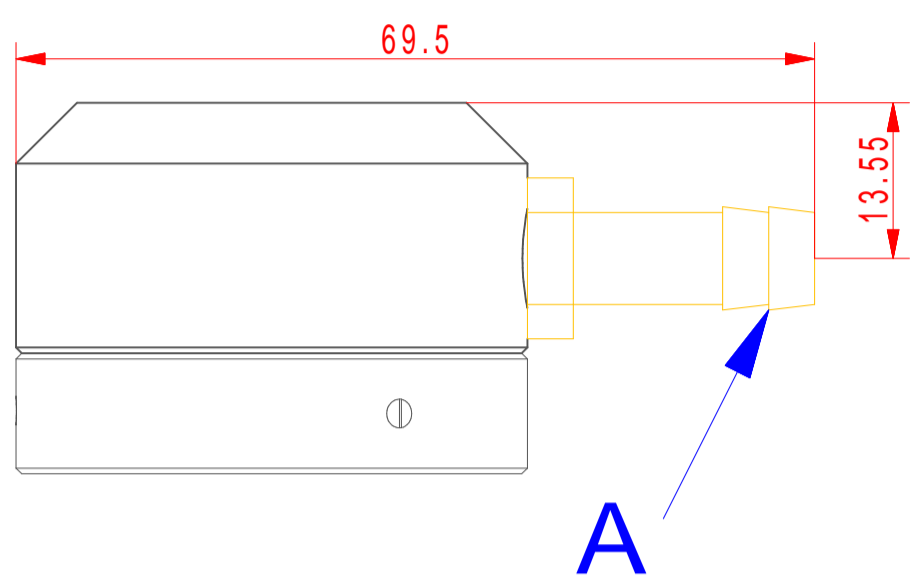
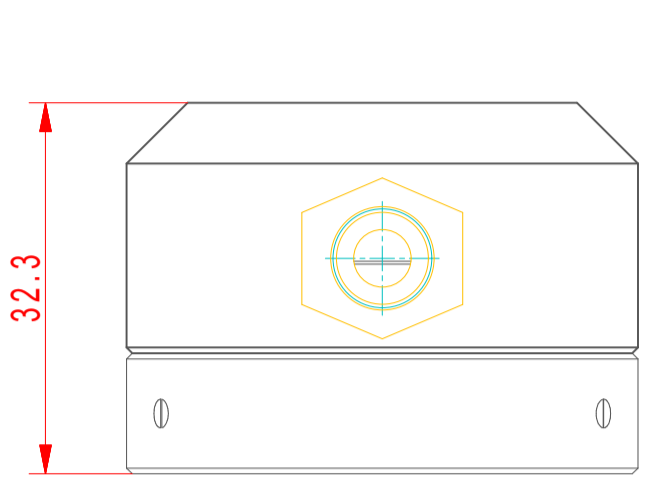

Empfohlener Spülluftdurchsatz: 1,5 m³/h
 Empfohlener Luftdruck: 0,5 bar

Recommended air flow: 1,5 m³/h
 Recommended air pressure: max. 0,5 bar

A. Schlauchanschluss mit
 Innendurchmesser 8mm/

Connection for hose with
 8mm inside diameter

Weitergabe und Vervielfältigung dieser Unterlage, sowie Verwertung und Mitteilung ihres Inhalts nicht gestattet, soweit nicht ausdrücklich zugestanden. Alle Rechte vorbehalten.

		Maße in mm Dimensions in millimeters	Zul. Abw. f. Maße ohne Toleranzang. General tolerances	Fertigzustand finished condition	Maßstab Scale 1 : 1	Menge Quantity -
					Rohstoff/Raw material Rohteil-Nr./Raw piece No. .	Aluminium/Messing-Brass
					Gewicht/Weight:	0,1Kg
					Benennung/Designation	
					BL11-00 Blasvorsatz Air Purge	
					Sachnummer/Part-No.	Blatt Sheet 1
					ZN0037	von of 1
Ausg. Issue	Änderung Modification	Datum Date	Name Name	Dateiname Filename	Ursprung Source	MegaCAD
				ZN003700_Blasvor...Prt		

